



Omni® Ball Valve

Standard Features (Sizes 3/8" – 3")

- Blocks in two directions
- Rugged structure
- Unibody construction
- Compact, low profile, short face-to-face dimensions
- PTFE seat backed by EPDM for low stem torque
- Rated for full vacuum service

Options

- FKM backing cushions and O-ring
- Electrically actuated

Pressure vs. Temperature (PSI, WATER, NON-SHOCK)

NOMINAL SIZE		PVC		CPVC		
		30° F 120° F	30° F 120° F	121° F 140° F	141° F 175° F	176° F 195° F
INCHES	mm					
3/8-2	13-50	150	150	120	90	60
3	80	150	150	120	90	60

Sample Specification

All OMNI® ball valves size 3/8" - 3" shall be of one-piece compact design non-union type. All O-rings shall be EPDM or FKM with PTFE seats. Seats must have elastomeric backing cushions of the same material as the valve seals. PVC conforming to ASTM D1784 Cell Classification 12454-A, and CPVC conforming to ASTM D1784 Cell Classification 23567-A. Valve shall be rated 150 psi at 70°F, as manufactured by Asahi-America, Inc.

Dimensions (Sizes 3/8" – 3")

NOMINAL SIZE		SOCKET				THREADED								NOMINAL SIZE		SOCKET THR'D		NOMINAL SIZE		Cv
		ASTM SCH 40																		
INCHES	mm	d1	d2	l	L	d1	l	L	d	A	D	D1	h							
3/8	13	0.687	0.671	0.59	3.35	3/8-18 NPT	0.59	3.35	0.51	2.36	1.22	1.38	1.65	3/8	13	0.22	3/8	13	7.7	
1/2	13	0.848	0.836	0.69	3.82	1/2-14 NPT	0.59	3.82	0.59	2.76	1.22	1.38	1.73	1/2	13	0.26	1/2	13	14	
3/4	20	1.058	1.046	0.72	4.02	3/4-14 NPT	0.67	4.06	0.79	3.15	1.46	2.17	2.17	3/4	20	0.55	3/4	20	29	
1	25	1.325	1.310	0.87	4.49	1-11 1/2 NPT	0.79	4.45	0.98	3.15	1.77	2.36	2.36	1	25	0.88	1	25	47	
1 1/4	30	1.670	1.655	0.94	5.00	1 1/4-11 1/2 NPT	0.87	5.00	1.22	3.74	2.13	2.76	2.76	1 1/4	30	1.21	1 1/4	30	72	
1 1/2	40	1.912	1.894	1.09	5.98	1 1/2-11 1/2 NPT	0.98	5.94	1.38	4.33	2.50	2.99	2.99	1 1/2	40	1.32	1 1/2	40	140	
2	50	2.387	2.369	1.16	6.93	2-11 1/2 NPT	1.10	6.97	1.77	4.33	3.01	3.31	3.31	2	50	2.20	2	50	185	
3	80	3.516	3.492	1.87	9.29	3-8 PT	1.17	9.29	2.70	7.87	4.25	4.88	4.88	3	80	6.61	3	80	410	

Omni® Ball Valve

Specifications

- Sizes:** 3/8" – 3"
Models: Socket and Threaded
Bodies: PVC, CPVC
Seats: PTFE backed with EPDM
Seals: EPDM

Omni® is a Trademark of Asahi/America, Inc.

Parts List (Sizes 3/8" – 3")

PARTS			
NO.	DESCRIPTION	PCS.	MATERIAL
1	Body	1	PVC, CPVC
2	Ball	1	PVC, CPVC
3	End Connector	1	PVC, CPVC
4	Stem	1	PVC, CPVC
5	Handle	1	ABS
6	Seat	2	PTFE
7	Cushion	2	EPDM, Others
8	O-Ring	1	EPDM, Others
1a	Ring*	2	304 Stainless Steel

*Used for CPVC body, threaded end, 1/2" - 1"

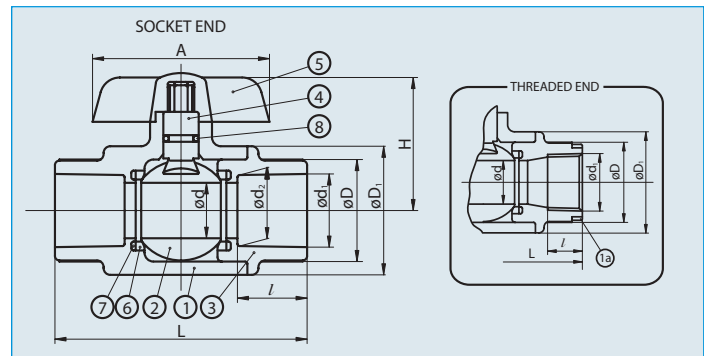

Weight (LBS.) Cv Values