

Type 56 – Gear Operated Butterfly Valves

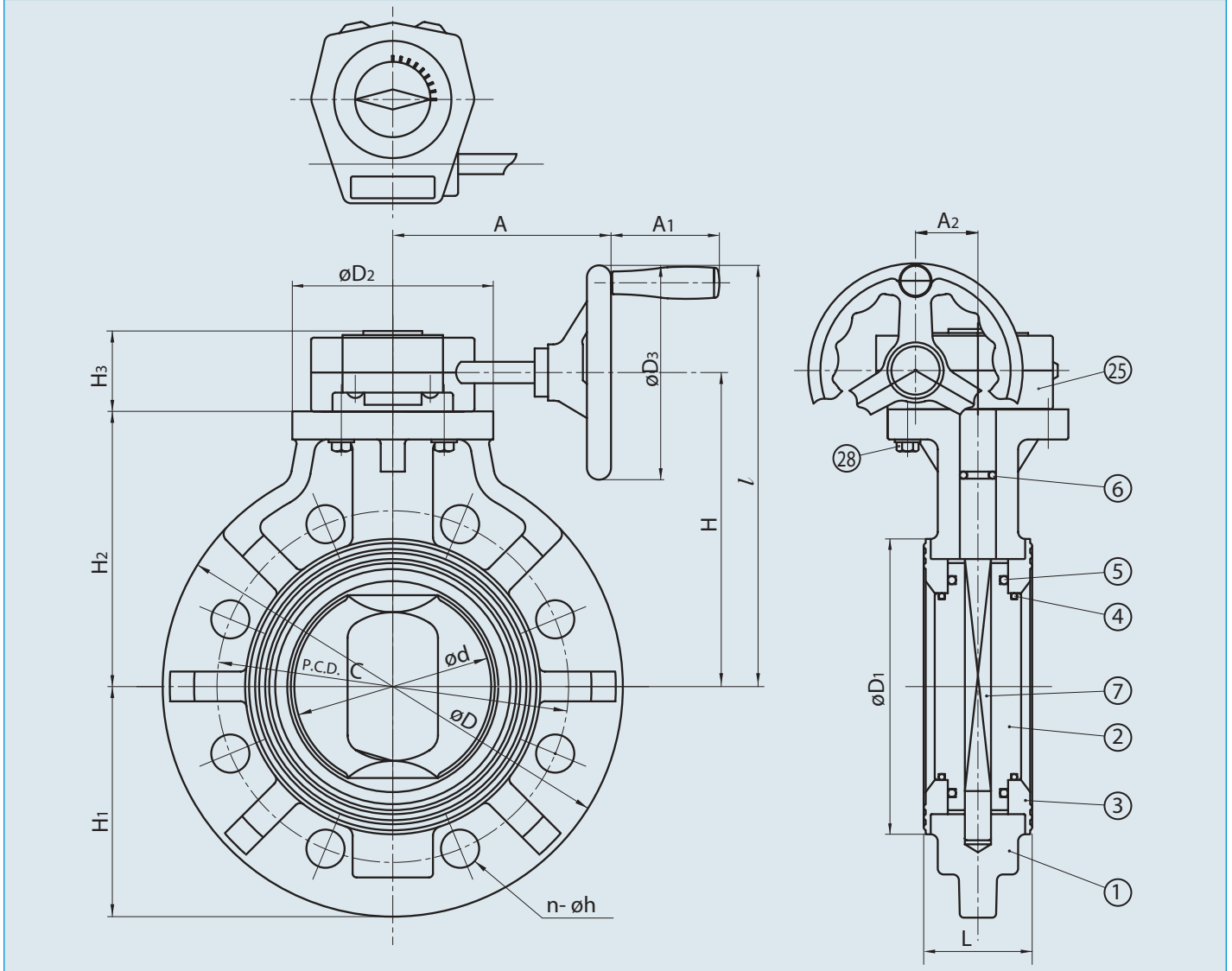

Dimensions (Sizes 1- 1/2" – 16") (NOTE: GEAR OPERATED VALVE IS STANDARD 8" – 16"; SIZES 1-1/2 " – 6" ARE OPTIONS.)

NOMINAL SIZE		ANSI CLASS 150																	
INCHES	mm	d	C	n	h	D	D1	D2	D3	L	H	H1	H2	H3	l	A	A1	A2	
1 1/2	40	1.85	3.88	4	0.62	5.91	3.23	3.94	6.30	1.54	4.88	2.95	3.74	2.36	8.03	6.57	3.15	1.85	
2	50	2.24	4.75	4	0.75	6.50	3.43	3.94	6.30	1.65	5.12	3.27	3.98	2.36	8.27	6.57	3.15	1.85	
2 1/2	65	2.80	5.50	4	0.75	7.28	4.41	3.94	6.30	1.81	5.55	3.66	4.41	2.36	8.70	6.57	3.15	1.85	
3	80	3.15	6.00	4	0.75	7.87	4.84	3.94	6.30	1.81	5.83	3.94	4.69	2.36	8.98	6.57	3.15	1.85	
4	100	4.13	7.50	8	0.75	9.02	5.79	3.94	6.30	2.20	6.54	4.53	5.39	2.36	9.69	6.57	3.15	1.85	
5	125	5.16	8.50	8	0.88	10.00	7.09	5.51	6.30	2.60	7.60	5.00	6.46	2.36	10.75	6.57	3.15	1.85	
6	150	6.06	9.50	8	0.88	11.22	8.27	5.51	6.30	2.80	8.11	5.63	6.97	2.36	11.26	6.57	3.15	1.85	
8	200	8.03	11.75	8	0.88	13.39	10.12	7.87	6.30	3.43	9.37	6.69	8.23	2.36	12.52	6.57	3.15	1.85	
10	250	10.08	14.25	12	1.00	15.98	12.44	7.87	7.87	4.33	10.63	7.99	9.49	2.36	14.57	7.83	3.74	2.36	
12	300	12.60	17.00	12	1.00	19.02	14.57	9.25	9.84	5.08	12.87	9.53	11.73	2.72	17.80	8.35	3.74	2.99	
14	350	14.37	18.75	12	1.12	20.47	16.54	9.25	9.84	5.08	13.19	10.24	12.05	2.72	18.11	8.35	3.74	2.99	
16	400	15.98	21.25	16	1.12	23.62	18.50	9.25	9.84	6.65	14.69	11.81	13.54	2.72	19.61	8.35	3.74	2.99	

Type 56 – Gear Operated Butterfly Valves

Parts List (Gear: Sizes 1-1/2" – 16")

PARTS			
NO.	DESCRIPTION	PCS.	MATERIAL
1	Body	1	PVC, PP, PVDF
2	Disc	1	PVC, PP, PVDF
3	Seat	1	EPDM, FKM, Others
4	O-Ring (A)	2	EPDM, FKM, Others
5	O-Ring (B)	2	EPDM, FKM, Others
6	O-Ring (C)	1	EPDM, FKM, Others
7	Stem**	1	Stainless Steel 316, 403
25	Gear Box	1	Diecast Aluminum Alloy*
28	Bolt(C)	4	Stainless Steel 304
1a	Ring	2	Steel

*With powder coat finish

** 14" and 16" 403 SS

Troubleshooting

What if fluid still flows when valve is closed?

1. Make sure lever or gear is in a fully closed position (gear type may require travel stop adjustment).
2. Liner is damaged or worn. Replace liner.
3. Disc is damaged or abraded. Change disc.
4. Foreign material is caught between seat and disc. Remove the substance.
5. Mating flange bolts either over-tightened or unevenly tightened. Retighten properly.

What if fluid leaks outside between seat and mating flange?

1. Seat damage. Change seat.
2. Mating flange bolts not tightened with proper torque or unevenly tightened. Retighten to the appropriate torque.

What if valve does not operate smoothly?

1. Foreign material is caught between disc and seat. Remove the material and clean.
2. Lever or gearbox is damaged. Replace.
3. Mating flange bolts over-tightened. Retighten.

Sample Specification

All solid thermoplastic butterfly valves sizes 1-1/2" thru 16" shall be of the TYPE 56 lined body design and bubble-tight seal (meeting or exceeding Class VI as defined by American National Standard Institute) with only the liner and disc as wetted parts. The lever handle (sizes 1-1/2" thru 8") shall have a molded provision for a padlock. Gear operators shall be worm gear design, self locking with diecast aluminum body and corrosion resistant powder coat finish. The disc shall be of solid, abrasion-resistant plastic, have double o-ring seals on top and bottom trunnions of the same material as the valve liner. Liner shall be molded and formed around the body, functioning as gasket seals with convex ring design on each side of the valve for lower bolt tightening torque. Stem shall be of 316/403 stainless steel, non wetted and have engagement over the full length of the disc. Valves shall have a molded ISO bolt pattern conforming to 5211/I – 5211/II on top flange for actuator mount. PVC shall conform to ASTM D1784 Cell Classification 12454-A, PP conforming to ASTM D4101 Cell Classification PPO210B67272, and PVDF conforming to ASTM D 3222 Cell Classification Type II. All PVC (1-1/2" thru 14" only), PP and PVDF body valves shall be rated to 150 psi sizes 1-1/2" thru 10", 100 psi sizes 12" & 14" and 85 psi size 16" at 70 degrees F. Butterfly valves shall be wafer style, as manufactured by Asahi/America.

Caution

- Never remove valve from pipeline under pressure.
- Always wear protective gloves and goggles.

Cv Values

NOMINAL SIZE		Cv (at various opening degrees)		
INCHES	mm	30°	60°	90°
8	200	106	1425	2500
10	250	270	1476	3600
12	300	408	2140	5160
14	350	535	2770	6440
16	400	750	3760	8340

Pressure vs. Temperature (PSI, WATER, NON-SHOCK)*

BODY		PVC			PP			PVDF		
DISC		PP			PP			PVDF		
NOMINAL SIZE		30° F	121° F	141° F	-5° F	141° F	-5° F	141° F	176° F	211° F
INCHES	mm	120° F	140° F	175° F	140° F	175° F	140° F	175° F	210° F	250° F
8	200	150	40	20	150	85	150	85	75	60
10	250	150	40	20	150	85	150	85	75	60
12	300	100	30	15	100	60	100	60	45	30
14	350	100	30	7	100	45	100	45	30	15
16	400	NA	NA	NA	85	45	85	45	30	15

* For lug style data consult factory

Wt. (LBS) / Vacuum Service

NOMINAL SIZE		GEAR OPERATED	NOMINAL SIZE		VACUUM SERVICE (INCHES OF MERCURY)
INCHES	mm		INCHES	mm	
8	200	24.25	8	200	-27.56
10	250	41.00	10	250	-27.56
12	300	58.42	12	300	-23.62
14	350	66.14	14	350	-23.62
16	400	79.40	16	400	-23.62