



**FRP "Giant" Butterfly Valve**

# FRP Butterfly Valve

**Specifications**

**Sizes:** 28" – 60"  
**Model:** Wafer Style  
**Operator:** Gear  
**Body:** FRP (Fiber glass reinforced polyester)  
**Disc:** FRP  
**Seat:** FKM, EPDM  
**Stem:** Stainless steel 403

**Standard Features**

- Corrosion resistant FRP body and disc
- Significantly lighter than metallic butterfly valves
- Stainless steel stem has full engagement over the entire length of the disc and is a non-wetted part, totally isolated from the media
- Only disc and seat are wetted parts
- Bubble tight shut-off

**Sample Specification**

All FRP (Fiber-Glass Reinforced Polyester) butterfly valves sizes 28" thru 60" shall be of the lined body design and bubble-tight seal (meeting or exceeding Class VI as defined by American National Standard Institute) with only the liner and disc as wetted parts. Gear operators shall be worm gear design, self locking with cast iron body and corrosion resistant powder coat finish. The disc shall be of solid, abrasion-resistant FRP, have double O-ring seals on top and bottom trunnions of the same material as the valve liner. Liner shall be molded and formed around the body, functioning as gasket seals with convex ring design on each side of the valve for lower bolt tightening torque. Stem shall be of 403 stainless steel, non wetted and have engagement over the full length of the disc. All valves shall be rated to a maximum of 106 psi at 70 degrees F. Butterfly valves shall be wafer style, as manufactured by Asahi/America, Inc.

**Parts List (Gear: 28" – 60")**

PARTS			
NO.	DESCRIPTION	PCS.	MATERIAL
1	Body	1	FRP
2	Disc	1	FRP
3	Seat	1	EPDM, FKM
8	Stem	1	Stainless Steel 403
17	Gear Box	1	Cast Iron (Epoxy Powder Coating)

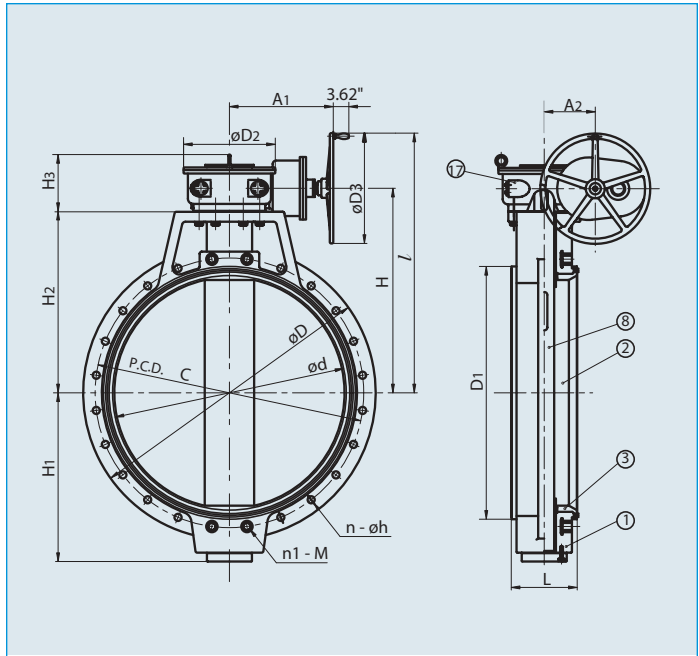

**Dimensions (Sizes 36" – 60") 28" AND 32" CONSULT FACTORY Cv/Wt./ Pres. vs. Temp.**

NOMINAL SIZE		ANSI Class 150															GEAR BOX MODEL NO.	Cv	WT. (LBS.)	PRES. VS. TEMP. 30° F 120° F
INCHES	mm	d	C	n - øh	n1 - M	D	D1	D2	D3	L	A	A1	H1	H2	H3	H				
36	900	34.25	42.75	28 - ø1.63	4-M 1-1/2	45.98	38.50	13.78	25.00	9.45	15.83	11.22	26.06	27.76	9.76	31.38	BRF-10	55,000	1,080	110
40	1000	38.19	49.25	34 - ø1.63	4-M 1-1/2	49.69	42.52	18.11	25.00	11.81	22.20	9.53	28.43	29.53	10.39	33.54	BRF-10	70,000	1,455	110
48	1200	46.06	56.00	40 - ø1.63	4-M 1-1/2	59.49	51.18	18.11	25.00	13.78	22.20	9.53	34.33	35.04	10.39	39.06	BRF-20	100,000	2,425	110
60	1500	58.27	69.25	48 - ø1.63	4-M 1-3/4	72.99	63.39	27.56	25.00	15.00	28.23	14.65	42.13	45.08	16.61	51.26	BRF-50	164,000	4,409	110